

# **SPECIFICATIONS**

---

## **- ELECTRIC BI-FOLD SYSTEM**

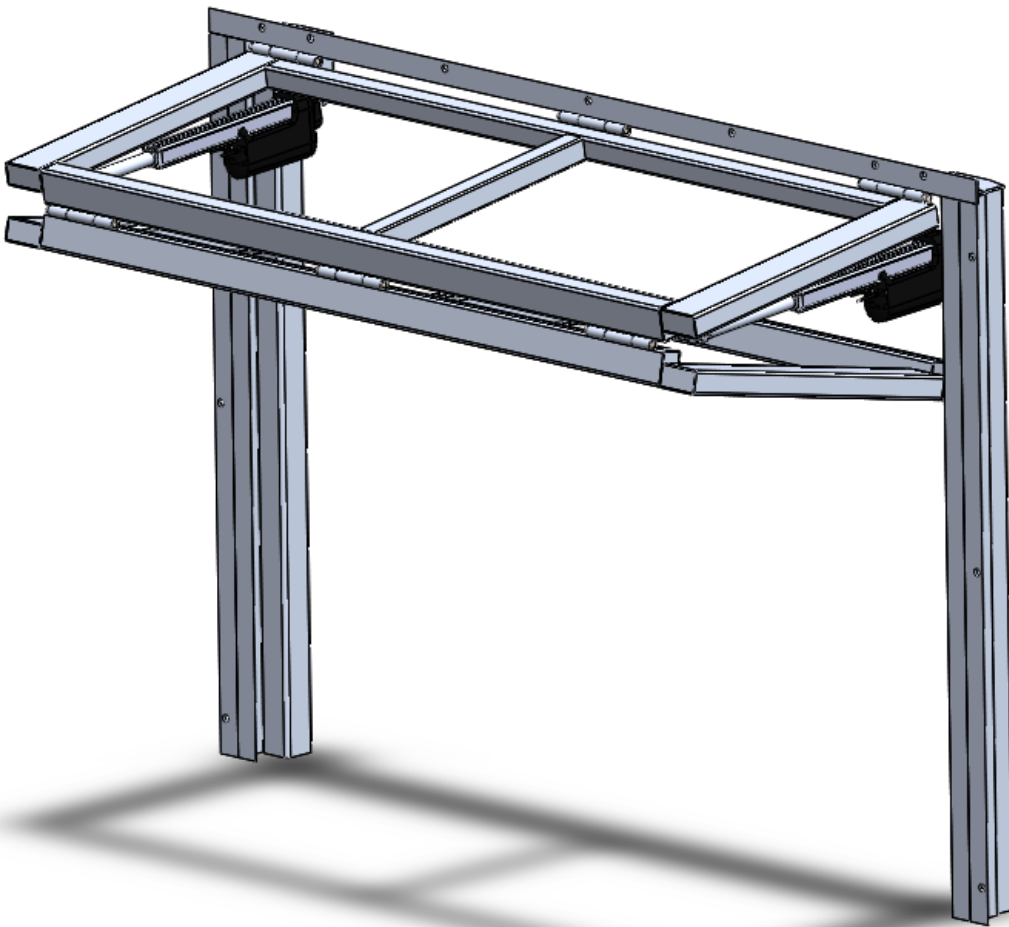



## PART 1 - GENERAL

### 1.01 DESCRIPTION

#### A. General

1. Furnish Electric Bi-Fold System complete from one manufacturer. Provide all labor, materials, tools, and equipment to furnish the Electric Bi-Fold System complete as herein specified.

### 1.02 RELATED WORK BY OTHERS

- A. Preparation of opening including jambs and header will be by General Contractor. Any deviation of site conditions contrary to approved shop drawings must be called to the attention of the architect.
- B. All header, blocking, support structures and jambs as required.
- C. Paint or otherwise finishing all trim and other materials adjoining door.
- D. Provide hydraulic fluid in quantity necessary for proper system operation.

### 1.03 SUBMITTALS

#### A. Product Data

1. Submit manufacturer's product data and roughing-in diagrams.
2. Complete shop drawings are to be provided prior to fabrication indicating construction and installation details.

### 1.04 QUALITY ASSURANCE

- A. Provide each Electric Bi-Fold System as a complete unit by one manufacturer, including frame, operable panel, glass and glazing, brackets, guides, hardware, operators, and installation accessories to suit opening.
- B. Wind Loading: Design and reinforce Electric Bi-Fold system to withstand a wind loading pressure to comply with state and federal code requirements.
- C. Preparation of the opening shall conform to current criteria set forth by the International and Standard Building Code.

### 1.05 PRODUCT DELIVERY, STORAGE AND HANDLING

- A. Proper storage of the system before installation and continued protection during and after installation will be the responsibility of the general contractor.

### 1.06 WARRANTY

- A. All materials and components, supplied by Crown, shall be guaranteed against defects in material and workmanship, for a period of one year from date of delivery.
- B. Materials and components supplied by other than Crown is not included in this warranty.
- C. Reference std. Crown warranties for further information.

**PART 2 - PRODUCTS****2.01 ACCEPTABLE MANUFACTURERS**

- A. Subject to compliance with requirements, manufacturers offering products which may be incorporated into the work, include, but are not limited to, the following:

**Crown Doors, LLC**  
**135 McLeod Avenue South**  
**Plato, MN. 55370**  
**(320) 238-2616**  
[www.crowndoors.com](http://www.crowndoors.com)  
[info@crowndoors.com](mailto:info@crowndoors.com)

- B. Upon compliance with all the criteria specified in this section, manufacturers wishing to bid products similar to the product specified must submit to the architect - 10 days prior to bidding - complete data in support of compliance. The submitting manufacturer guarantees the proposed substituted product complies with the product specified and as detailed on the drawings.

**2.02 MATERIALS**

- A. Product to be Electric Bi-Fold System as furnished by Crown Doors, LLC
1. Construct operable panel and frame sections with structural steel (of ASTM-A500 grade minimum) framing to comply with applied wind code.
    - Optional: 304 stainless steel framing for highly corrosive environments.
  2. Operable panels and frame shall be constructed of structural steel tubing, and other structural steel shapes, and shall be designed to the same loading requirements for live, dead and wind loads as the surrounding construction.
  3. System shall be designed so that no center "cane bolt" is required in the floor.
  4. Operable panels and frame shall be factory-welded at all joints and connections, with smooth welds not to exceed 1/4" [6] thickness.
  5. Inside-Sash (infill) glass retainer system shall be factory pre-installed and seam-sealed, and necessary setting blocks, spacers, butyl and foam tape shall be supplied.
  6. System frame, operable panels, and factory pre-installed, inside-sash glass retainer shall be primed with gray-zinc, powder-based, epoxy primer, and finished with manufacturer's standard powder-coat.
  7. Factory-Supplied neoprene seals/weather stripping will be shipped loose for field-install to protect against damage during transport.
- B. Electric Bi-Fold System shall be operated by linear actuators that are mechanically fastened to the panel frames.
1. Actuators are to be located on the top half of the door, only. Actuators will be designed to carry the

required loads during operation, open position, and closed position.

2. Speed: Approx. 30-40 seconds to fully-open or fully-closed position.
  3. System shall be locked closed by means of the linear actuators drawing operable panels against system frame; No additional locking mechanisms necessary.
- C. Power: Standard 120v, single-phase, 10-amp.
1. Constant contact push-button or key-switch controls for separate mounting.
  2. Control switch to operate (2) linear actuators which open and close the system. System wire box, control switch and actuators are to be pre-wired, factory tested and provided with supply cables for final hook-up (by others).
  3. "Open-Close" control units will be wired for constant-hold operation.
  4. Incoming electrical source to wire box to be supplied by others.
  5. Each linear actuator shall have thermal overload protection for the motor.
- D. Finishes
1. Entire system frame, operable panels, and factory pre-installed, inside-sash glass retainer shall be primed with gray-zinc, powder-based, epoxy primer, and finished with manufacturer's standard powder-coat.
    - Optional Finishes
      - i. RAL powder-coat colors in gloss or satin
      - ii. Custom matched powder-coat color
- E. Available Accessories/Options
1. Photoelectric or lead-edge pressure sensor that stops (or stops and reverses) the downward movement of the door/window.
  2. Warning horn/Strobe light assembly
  3. Remote receiver w/transmitter
  5. External, weather-resistant, "open-close" control wired for constant-hold

### 2.03 OPERATION

- A. The Electric Bi-Fold System shall be extended/retracted in the opening using a constant-contact push-button or key switch, operating linear actuators mounted to the system frame.

**PART 3 - EXECUTION**

## 3.01 SAFETY

- A. System to have hand-crank manual operation available in case of a power outage.
- B. Photoelectric or lead-edge pressure sensor optional.

## 3.02 INSTALLATION

- A. Installation of the Electric Bi-Fold System shall be by a contractor familiar with this type of installation and be in strict accordance with the approved build drawings and manufacturers standard printed specifications, instructions, and recommendations. All moving parts will be left in good operating condition.
- B. Permanent or temporary electric wiring shall be brought to the power unit location before installation. After the Electric Bi-Fold System is installed, the general contractor assumes the responsibility of any damage to the system or system components during construction until the building is turned over to the owner.

## 3.03 CLEANING

- A. All surfaces shall be wiped clean and free of handprints, grease, and oil.

## 3.04 TRAINING

- A. Installer shall demonstrate proper operation and maintenance procedures to owner's representative.
- B. Operating keys and owner's manual shall be provided to owner's representative.